

Katalogový list

platný od: 1/1/22

+GF+

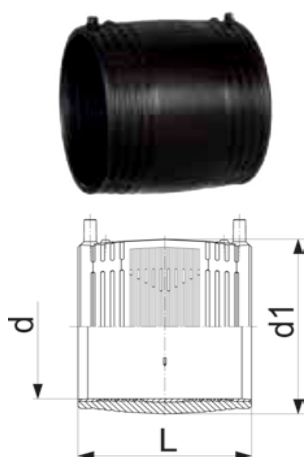

Elektrospojka SDR 17

- PE 100 SDR 17 (ISO S8)
 - 5 bar plyn / 10 bar voda
 - 4mm svařovací konektory
 - Kontrolní výronek s ochranou proti vytečení taveniny
 - Odstranitelný doraz do d 160 mm
- * pouze pro vodu

d (mm)	obj. číslo	hmotn. (kg)	d1 (mm)	L (mm)	SDR trubky
160	753 911 817	1.017	186	180	9-26
180	753 911 818	1.434	213	192	9-26
200	753 911 819	1.726	233	206	9-26
225	753 911 820	2.545	261	225	9-26
250	753 911 821	4.616	304	248	9-26
280	753 911 822	5.606	340	252	9-26
315	753 911 823	6.100	382	267	9-26
355	753 911 804	9.522	416	291	17-33
400	753 911 805	18.000	467	295	17-33
450	753 911 806	16.000	526	327	17-33
500	753 911 807	22.000	584	358	17-33
560	753 911 808	34.000	647	396	17-33
630	753 911 809	46.000	727	440	17-33
710	753 911 810	55.600	820	463	17-33
800	753 911 811	73.000	922	484	17-33
* 900	753 911 852	93.150	1030	550	9-26
* 1000	753 911 853	125.650	1143	600	9-26
* 1200	753 911 854	196.450	1370	650	9-26

Technické údaje jsou nezávazné. Konstrukční a rozměrové změny vyhrazeny.
Platí naše všeobecné obchodní podmínky.